



SCAN IT
TO KNOW MORE

Call 1860 500 2468 or
visit www.aosmithindia.com

Plot No. 300, Phase - II, KIADB Industrial Area, Harohalli, Kanakapura Taluk,
Ramanagara District, Karnataka - 562 112, India. CIN: U31909KA2006PTC040282

<https://www.facebook.com/aosmithin> | <https://twitter.com/AOSmithin>



Since 1874

Printed on-01/25

ACSmith | Water Heaters

Fit it & Forget it!



Since 1874

Explore Our Stylish Range of Water Heaters



SAY HELLO TO A. O. SMITH.

Founded in 1874 by Charles Jeremiah Smith, the A. O. Smith Corporation began as an engineering company in Milwaukee, Wisconsin. Today, we are the global leaders in making water heaters. This drives our pursuit for excellence when it comes to water purifiers as well. For the past 150 years, our singular purpose has been to create stellar products that deliver the best performance with the best technology. And to this day, we live strongly by that belief.

150 years of innovation.

A. O. Smith enjoys a rich history of achievements. A glimpse at our 150-year history reveals numerous engineering and technical achievements.



1874

Started operations

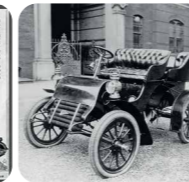

1889-1906

Foray into the bicycle industry and over the years became North America's largest automobile frame manufacturer



1936-1954

Patented the glass line technology and introduced the first glass-lined commercial water heater



1995

Joint venture in China



2008

Started operations in India

2010

Factory set up in Harohalli, near Bengaluru - Water Heater Manufacturing begins



2015

Entry in Water Purification-Pioneers in introducing the Hot Water feature



2020-2023

Launched industry-defining products in Water Heaters and Water Purifier series in India



2024

A. O. Smith celebrates 150 years of integrity, innovation and customer satisfaction in its business locations across the globe.



The Blue Diamond® Story.



A. O. Smith was credited with the invention of the glass-lined water heater tanks in 1936. After this, the next breakthrough was the Blue Diamond® technology in 2004. In this technology, a specially formulated glass frit is bonded to the steel through a complex process that is carried out at over 800°C. The Blue Diamond® Glass-Lining technology reduces scaling accumulation on the tank caused by minerals, corrosion due to hard water and leakage of heat into the atmosphere. It also enhances the strength and durability of the tank.

A. O. Smith water heaters come with Blue Diamond® Glass-Lining technology, replacing the earlier stainless steel water heaters that were prone to rusting, corrosion and scaling due to the contact between hot water and steel.

This **Blue Diamond® technology** provides twice the corrosion resistance compared to industry standards and increases the life span of the tank.

Setting Benchmarks*.

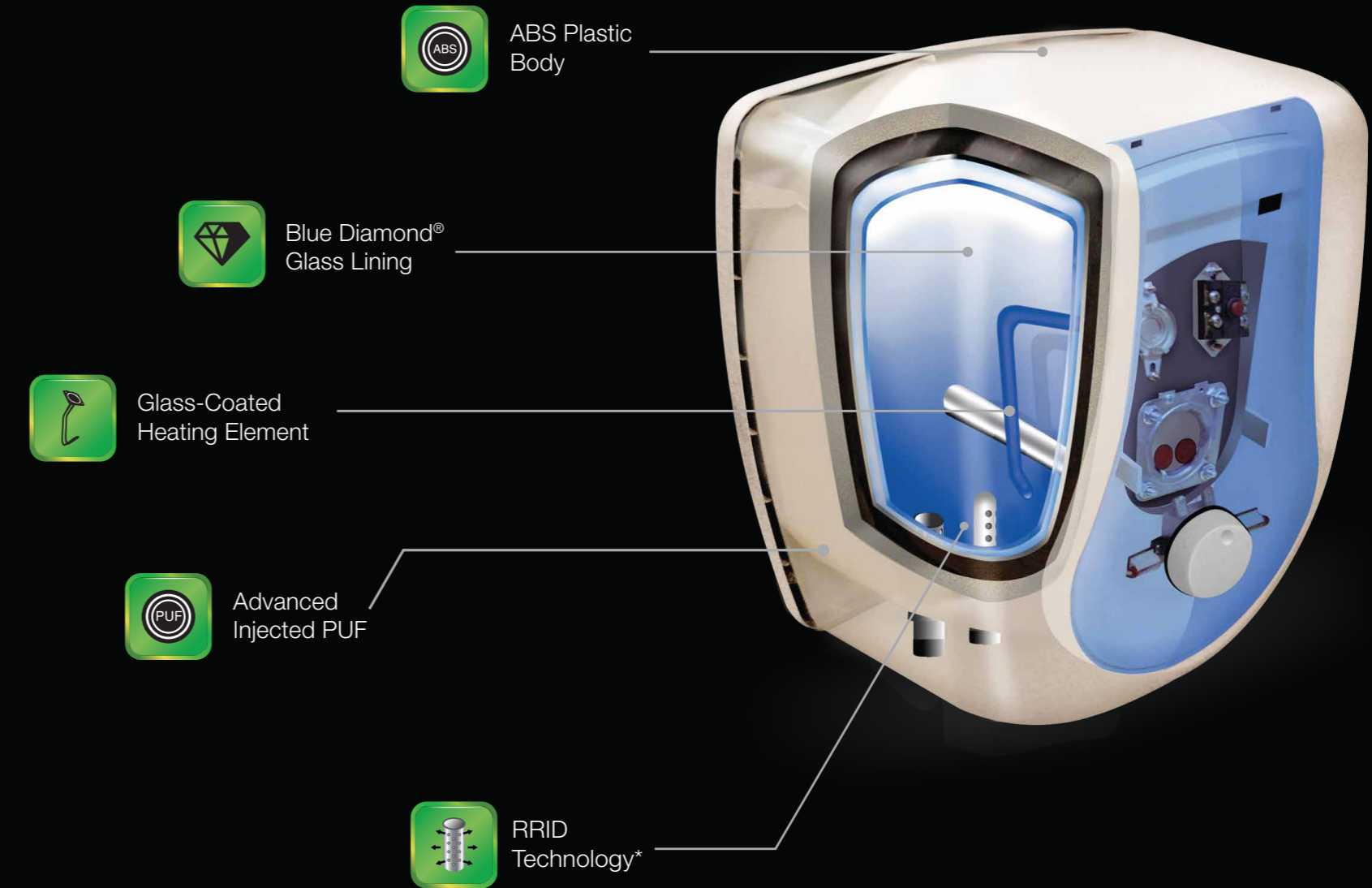

* Select features may vary based on models





xpress





Capacity : 6L, 10L, 15L, 25L
Product Color : White
Power(KW) : 3
Rated Water Pressure: 8 Bar
BEE Star Rating: 5

 **Smart Modes** enable you to customise your hot water requirements as you like it

 **Express Heat** with 33% faster heating than 2 kw water heaters.





 **Longer life** in toughest water conditions with Blue Diamond® glass lined tank

 **Long lasting** performance with glass coated incoloy heating element

 **Double Protection** of your family with thermalcut-out and safety valve.

 **Long-lasting Anode Rod** 2X lifespan as compared to normal magnesium rod.

Experience **SMART MODES***

-  SHOWER
-  BUCKET
-  PEDICURE
-  WASHING
-  MOPPING

Storage Water Heater

Product Dimensions

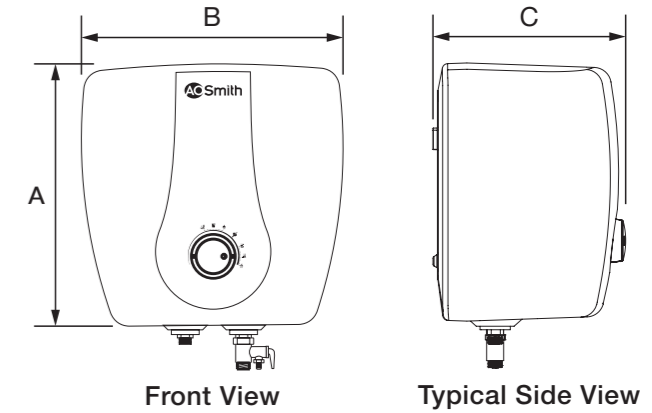

All Dimensions in mm

Model Name	A	B	C
XPRESS-006	317	317	258
XPRESS-010	373	373	277
XPRESS-015	373	373	348
XPRESS-025	444	444	383



Inner Tank	Glass Coated Heating Element	Product
7 years	4 years	2 years

* Please refer page No 33 for more details

TIME IS A LUXURY - XPRESS SERIES UNDERSTANDS IT

Our Xpress series values your time. This is why they give you hot water 33% faster compared to ordinary water heaters of 2KW. Adept with Smart modes to provide water as per application requirement, you'll be surprised at the amount of time these water heaters can save for you.



AESTHETICS AND PERFORMANCE REDEFINED

Finesse series equipped with Smart Modes facilitates hot water as per your requirement. With its best-in-class design, Blue Diamond Glass lining coupled with maximum energy efficiency, Finesse range of water heaters are built to last a lifetime and provide you a seamless bathing experience.

finesse



Capacity : 6L, 10L, 15L, 25L

Product Color : White

Power(KW) : 2

Rated Water Pressure: 8 Bar

BEE Star Rating: 5



Smart Modes enable you to customise your hot water requirements as you like it



Maximum energy savings with BEE 5 Star rating



Longer life in toughest water conditions with Blue Diamond® glass lined tank



Long lasting performance with glass coated incoloy heating element



Double Protection of your family with thermal cut-out and safety valve.



Long-lasting Anode Rod 2X lifespan as compared to normal magnesium rod.

Experience
SMART MODES*



SHOWER



BUCKET



PEDICURE



WASHING



MOPPING

Storage Water Heater

Product Dimensions

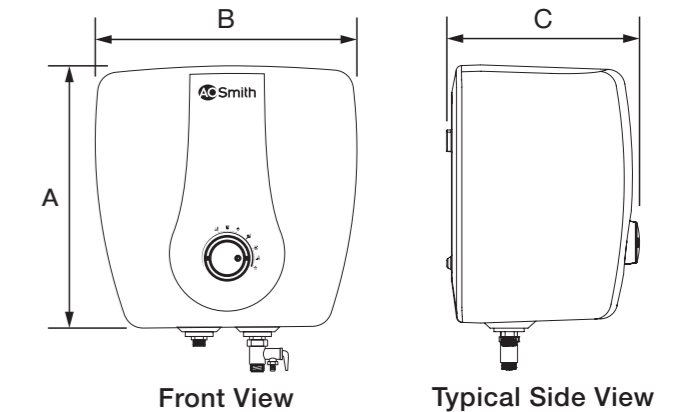

All Dimensions in mm

Model Name	A	B	C
FINESSE-006	317	317	258
FINESSE-010	373	373	277
FINESSE-015	373	373	348
FINESSE-025	444	444	383



Inner Tank	Glass Coated Heating Element	Product
7 years	4 years	2 years

* Please refer page No 33 for more details



Urbane



Capacity : 6L, 10L, 15L, 25L

Product Color : White

Power(KW) : 2

Rated Water Pressure: 8 Bar

BEE Star Rating: 5



Longer life in toughest water conditions with Blue Diamond® glass lined tank



Maximum energy savings with BEE 5 Star rating



Long lasting performance with incoloy heating element



Double Protection of your family with Thermal Cut-out and Safety Valve.



Long-lasting Anode Rod
2X lifespan as compared to normal magnesium rod



Inner Tank	Heating Element	Product
7 years	3 years	2 years

Storage Water Heater

Product Dimensions

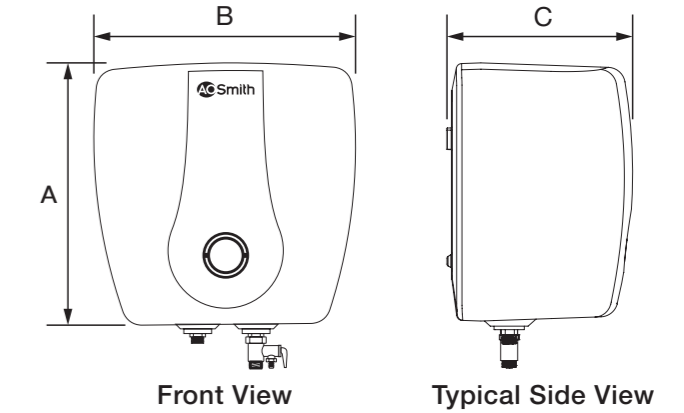

All Dimensions in mm

Model Name	A	B	C
URBANE-006	317	317	258
URBANE-010	373	373	277
URBANE-015	373	373	348
URBANE-025	444	444	383

*Please refer Page No 33 for more details

EFFICIENT AND DURABLE

With Blue Diamond® Glass lined tank, the Urbane series is designed to perform the best, even in toughest of water conditions.





HeatBot® WiFi





- Capacity :** 15L, 25L
- Product Color :** Silver
- Power(KW) :** 2
- Rated Water Pressure:** 8 Bar
- BEE Star Rating:** 3, 4

 **Operate your water heater** from anywhere with A. O. Smith smart app

 **Control your water heater** with Alexa voice integration

 **Smart Modes** enable you to customise your hot water requirements as you like it

 **Longer life** in toughest water conditions with Blue Diamond® glass lined tank

 **Long lasting** performance with glass coated incoloy heating element

 **Double Protection** for your family with thermal cutout and safety valve

Experience
SMART MODES*



SHOWER



BUCKET



PEDICURE



WASHING



MOPPING

Storage Water Heater

Product Dimensions

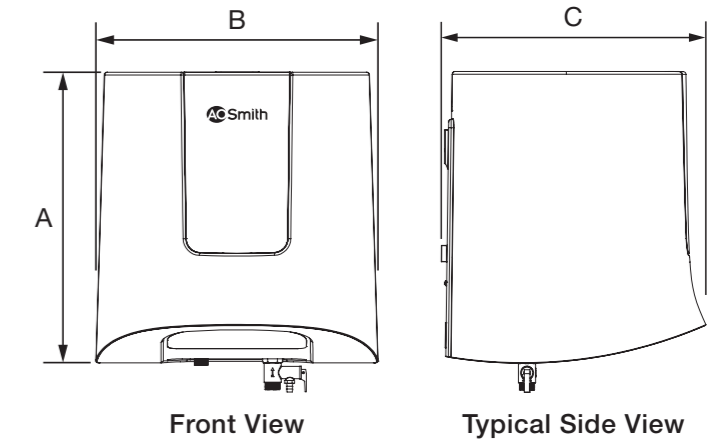

All Dimensions in mm

Model Name	A	B	C
SZS-WIFI-015	408	395	370
SZS-WIFI-025	486	444	408



Inner Tank	Extended Warranty* Heating Element	Product
7 years	2+2 years	2 years

* Please refer page No 33 for more details * Please refer warranty page for details

UPGRADE TO THE ART OF SMART BATHING

HeatBot series is the future of water heaters. You can control your water heater using mobile phone or Alexa. With its advanced features such as Smart modes, Smart scheduler & Energy tracker, be ready for an upgraded experience.

HeatBot® SZS-DG



Capacity : 15L, 25L
Product Color : Silver
Power(KW) : 2
Rated Water Pressure: 8 Bar
BEE Star Rating: 4

Longer life in toughest water conditions with Blue Diamond® glass lined tank

Energy meter to help you monitor energy utilisation*

Long lasting performance with glass coated incoloy heating element

Easy operation with Wireless Remote*

Long-lasting Anode Rod 2X lifespan as compared to normal magnesium rod.

Double Protection for your family with thermal cutout and safety valve

	Inner Tank	Extended Warranty* on Heating Element	Product
	7 years	2+2 years	2 years

Storage Water Heater

Product Dimensions

Front View **Typical Side View**

All Dimensions in mm

Model Name	A	B	C
SZS-DG-015	408	395	370
SZS-DG-025	486	444	408

* Please refer warranty page for details

HeatBot® SZS



Capacity : 15L, 25L
Product Color : Silver
Power(KW) : 2
Rated Water Pressure: 8 Bar
BEE Star Rating: 4

Longer life in toughest water conditions with Blue Diamond® glass lined tank

Easy access temperature control knob for choice of bathing water 25°C - 75°C

Long lasting performance with glass coated incoloy heating element

Double Protection for your family with thermal cutout and safety valve

Long-lasting Anode Rod 2X lifespan as compared to normal magnesium rod.

	Inner Tank	Extended Warranty* on Heating Element	Product
	7 years	2+2 years	2 years

Storage Water Heater

Product Dimensions

Front View **Typical Side View**

All Dimensions in mm

Model Name	A	B	C
SZS-015	408	395	370
SZS-025	486	444	408

* Please refer warranty page for details

Introducing Elegance Neo Series

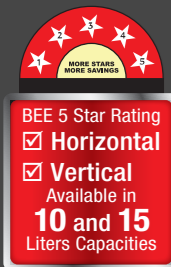

Elegance Neo series water heaters feature BEE 5 star rating and saves on energy costs. Blue Diamond® Glass lined Tank which gives **2X** corrosion resistance* and Glass coated Incoloy heating element ensures longer life even in toughest water conditions. What's more... with a compact & sleek design it elevates the décor of your bathroom.

elegance
Prime-Neo



Capacity : 10L,15L

Product Color : White

Power(KW) : 2

Rated Water Pressure: 8 Bar

BEE Star Rating: 5



Longer life with Blue Diamond® Glass Lining



Easily fits with compact and superior design



Superior performance with incoloy heating element



Enhanced hot water output with RRID Technology (Patent Applied)



Peace of mind with 7 years warranty on tank, 3 years on heating element and 2 years on product



Premium quality Rust-proof outer body



Inner Tank	Heating Element	Product
7 years	3 years	2 years

Storage Water Heater

Product Dimensions

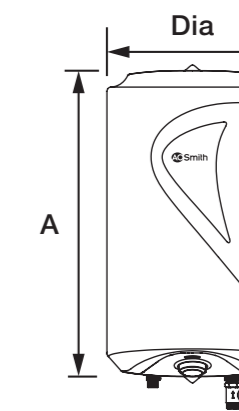

Vertical

All Dimensions in mm

Model Name	Dia	A
ELEGANCE PRIME NEO-010	310	437
ELEGANCE PRIME NEO-015	310	576

* Please refer warranty page for details

Flexible Installation



Compact size

- ✓ Ideal for Apartments
- ✓ Easily fits under false ceiling
- ✓ 310 mm Diameter

elegance
Slim-Neo



Capacity : 10L,15L
Product Color : White
Power(KW) : 2 3 (10L)
Rated Water Pressure: 8 Bar
BEE Star Rating: 5



Longer life with Blue Diamond® Glass Lining



Superior performance with incoloy heating element



Peace of mind with 7 years warranty on tank, 3 years on heating element and 2 years on product



Easily fits with compact and superior design



Enhanced hot water output with **RRID Technology** (Patent Applied)



Premium quality Rust-proof outer body



Inner Tank	Heating Element	Product
7 years	3 years	2 years

Storage Water Heater

Product Dimensions

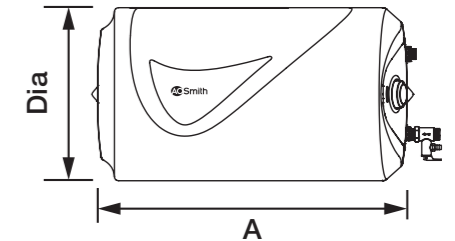

All Dimensions in mm

Model Name	Dia	A
ELEGANCE SLIM NEO-010	310	437
ELEGANCE SLIM NEO-015	310	576

*Elegance Slim Neo 15L is available in both with right-hand side and left-hand side inlet outlet configuration.

* Please refer warranty page for details



elegance Prime



Capacity : 15L, 25L
Product Color : White
Power(KW) : 2
Rated Water Pressure: 8 Bar
BEE Star Rating: 5



Longer life with Blue Diamond® Glass Lining



Premium quality
Rust-proof outer body



Enhanced hot water output
with **RRID Technology**
(Patent Applied)



Easily fits with compact
and superior design



Superior performance with
incoloy heating element



Dial Indicator
Heat as you like



Inner Tank	Heating Element	Product
7 years	3 years	2 years

Storage Water Heater

Product Dimensions

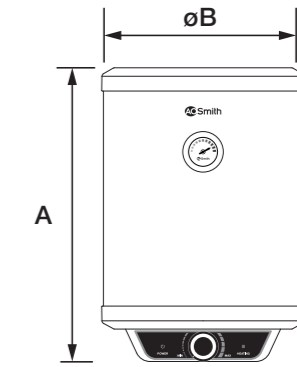

Elegance Prime

All Dimensions in mm

Model Name	A	B
ELEGANCE PRIME-015	504	344
ELEGANCE PRIME-025	564	369

HIGH PERFORMANCE DELIVERED.

Elegance prime water heaters delivers high performance and saves on energy costs. Blue Diamond® Glass lined Tank and Incoloy heating element ensures longer life even in toughest water conditions. With a sleek design it elevates the décor of your bathroom.

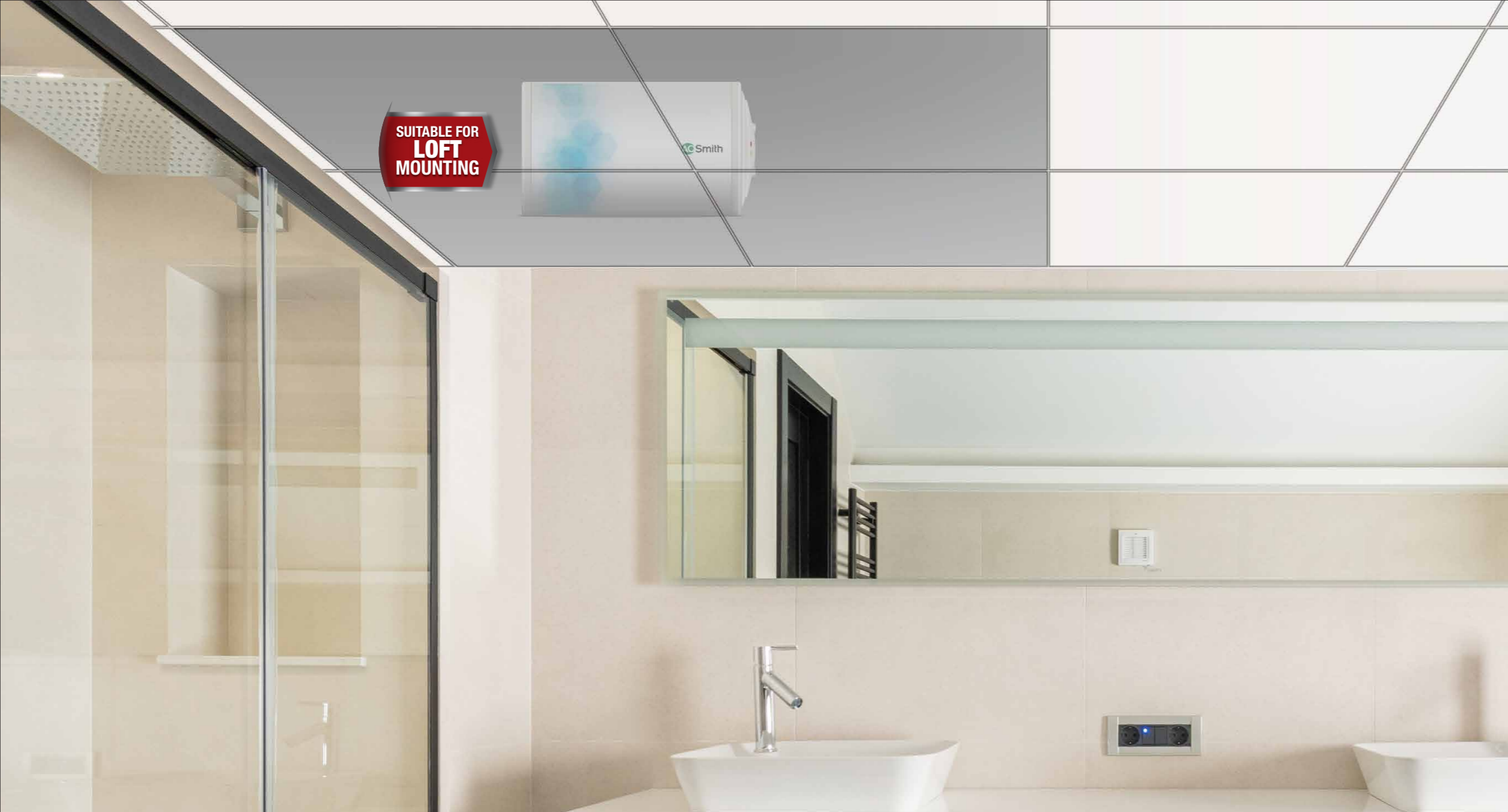

elegance *Slim*



- Capacity :** 15L, 25L
- Product Color :** White
- Power(KW) :** 2
- Rated Water Pressure:** 8 Bar
- BEE Star Rating:** 3



Compact size ergonomically and aesthetically designed water heater



Longer life in toughest water conditions with Blue Diamond® glass lined tank



Long lasting performance with glass coated incoloy heating element



Double Protection of your family with thermal cut-out and safety valve.



Long-lasting Anode Rod 2X lifespan as compared to normal magnesium rod.



Easy access temperature control knob for choice of bathing water 25°C - 75°C



Inner Tank	Extended Warranty* on Heating Element	Product
7 years	2+2 years	2 years

Storage Water Heater

Product Dimensions

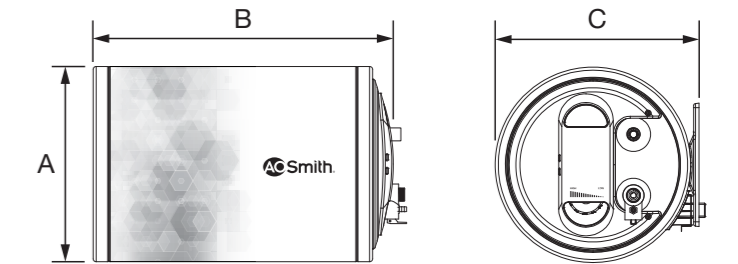

Elegance-Slim RHS

Typical Side View

All Dimensions in mm

Model Name	A	B	C
ELEGANCE-SLIM-015	320	492	334
ELEGANCE-SLIM-025	320	694	334

Elegance Slim models are available in both with right-hand side and left-hand side inlet outlet configuration.

COMPACT WATER HEATER WITH STATE-OF-ART TECHNOLOGY

With sleek design and horizontal orientation, Elegance-slim water heater are designed to fit into tight spaces. Available in RHS and LHS variants to facilitate hassle free installation.

* Please refer warranty page for details

HAS-X



Capacity : 35L, 50L
Product Color : White
Power(KW) : 2
Rated Water Pressure: 8 Bar
BEE Star Rating: 3

Longer life in toughest water conditions with Blue Diamond® glass lined tank

Easy access temperature control knob for choice of bathing water 25°C - 75°C

Long lasting performance with glass coated incoloy heating element

High energy efficiency with BEE 3 Star rating

Long-lasting Anode Rod 2X lifespan as compared to normal magnesium rod.

Double Protection of your family with thermal cut-out and safety valve.

	Inner Tank	Extended Warranty* on Heating Element	Comprehensive
	7 years	2+2 years	2 years

Storage Water Heater

Product Dimensions

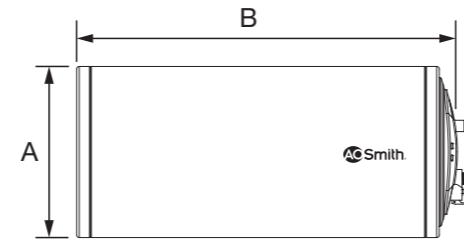

Front View

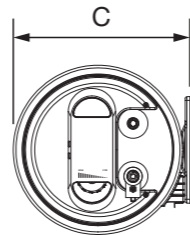

Typical Side View

All Dimensions in mm

Model Name	A	B	C
HAS-X-035	395	659	408
HAS-X-050	395	875	408

HAS-X models are available in both with right-hand side and left-hand side inlet outlet configuration.

* Please refer warranty page for details

HAS-CX | HSE-HAS



Capacity : HAS-CX 50L, HSE-HAS 70L, 100L
Product Color : White
Power(KW) : 2, 3, 3
Rated Water Pressure: 8 Bar
BEE Star Rating: 3, 3, 2

Longer life in toughest water conditions with Blue Diamond® glass lined tank

Easy access temperature control knob for choice of bathing water 25°C - 75°C

Long lasting performance with glass coated incoloy heating element

Ease of plumbing with bottom inlet outlet connection

Long-lasting Anode Rod 2X lifespan as compared to normal magnesium rod.

Dial Indicator Heat as you like

	Inner Tank	Extended Warranty* on Heating Element	Comprehensive
	7 years	2+2 years	2 years

Storage Water Heater

Product Dimensions

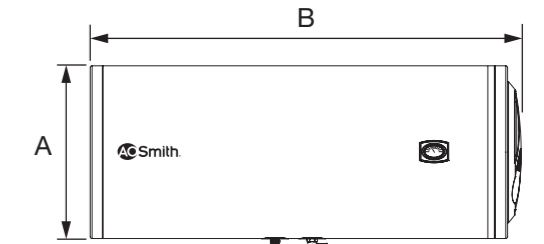

Front view

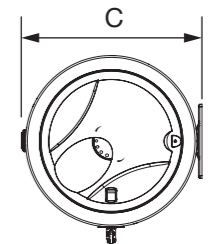

Right view

All Dimensions in mm

Model Name	A	B	C
HAS-CX-050	395	881	422
HSE-HAS-070	465	865	475
HSE-HAS-100	465	1156	475

Note: Select features in select models.

* Please refer warranty page for details

A DESIGN MARVEL

Sturdy tank construction with rust proof outer body ensures a lifetime performance. Saves on energy bills with 5 Star rating and it's sleek design also elevates your bathroom décor.



VAS-X



Capacity : VAS-X 35L, 50L
VAS-X1 50L

Product Color : White

Power(KW) : 2

Rated Water Pressure: 8 Bar

BEE Star Rating: 4



Compact size ergonomically and aesthetically designed water heater



Longer life in toughest water conditions with Blue Diamond® glass lined tank



High energy efficiency with BEE 4 Star rating



Long lasting performance with glass coated incoloy heating element



Double Protection of your family with Thermal Cut-out and Safety Valve.



Long-lasting Anode Rod 2X lifespan as compared to normal magnesium rod.



Inner Tank	Extended Warranty* on Heating Element	Comprehensive
7 years	2+2 years (VAS-X / VAS-X1)	2 years

Storage Water Heater

Product Dimensions

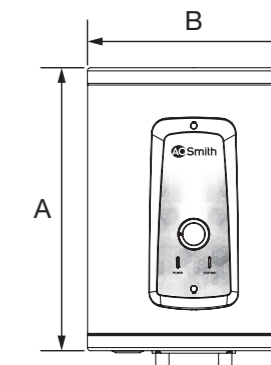

Front View

All Dimensions in mm

Model Name	A	B
VAS-X-035	620	395
VAS-X-050	838	395
VAS-X1-050	600	465

35L, 50L available in VAS-X series.

50L also available in VAS-X1 series

*Features available in select models only

* Please refer warranty page for details

JUST ZIP IT.

Bathing experience Redefined!

NEW



Digital Tankless Water Heater

Relaxing Bath | Smart display | Compact Size
Instant Heating | Constant Temperature

ZIP



Product Color : White,
(Silver 7.5, 9.0)

Power(KW) : 5.5, 7.5, 9.0

Rated Water Pressure: 6 Bar



Always be in control with Smart Display



Easy to use touch control



Compact size to suit installation of your choice**



Get Constant hot water with high powered heating element



Save energy with automatic power control



Superior Safety for your family with Digital Thermostatic control & Thermal cut out.



Comprehensive

2 years

Instant Water Heater

Product Dimensions

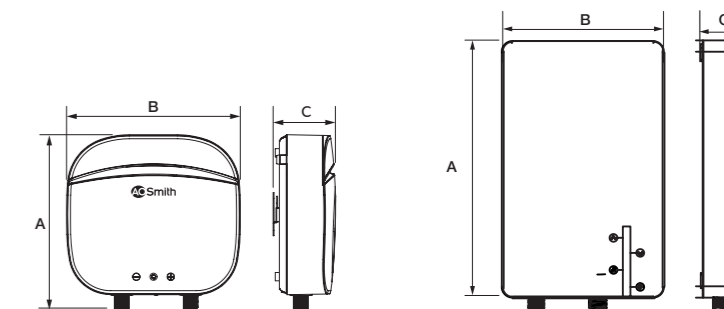

5500 Watts

7500 & 9000 Watts

All Dimensions in mm

Model Name	A	B	C
ZIP-5.5	252	250	90
ZIP-7.5	360	220	90
ZIP-9.0	360	220	90

* Please refer warranty page for details



WHY SETTLE FOR ORDINARY?

The **MiniBot® instant water heater** is a masterpiece with an outstanding design and cutting edge technology, redefining the instant water heater category. You may say it's a perfect balance of form and function that will make your bathroom look magnificent and extraordinary. That's why we say... **Why Settle For Ordinary?**

MiniBot®



Capacity : 3L

Product Color : White | Black

Power(KW) : 3 | 4.5

Rated Water Pressure: 8 Bar



Beautifies your bathroom with modern minimalistic design



Get instant hot water with glass coated heating element



Longer life in toughest water conditions with Blue Diamond® glass lined tank



Designed for high rise buildings with 8 bar pressure rating

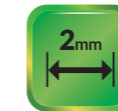

Stronger construction quality with tank thickness of 2 mm, **2X compared** to an ordinary instant water heater



Inner Tank	Extended Warranty* on Heating Element	Comprehensive
5 years	2+1 years	2 years

Instant Water Heater

Product Dimensions

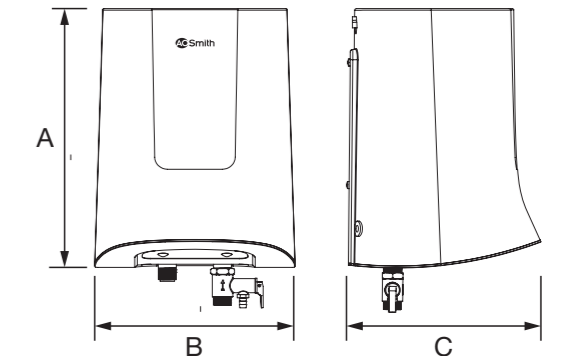

All Dimensions in mm

Model Name	A	B	C
MiniBot®	317	236	228

* Please refer warranty page for details

Introducing
FAST-ON
Instant Water Heater



5
Liters



FAST-ON® - 5L



Capacity : 5L
Product Color : White Black
Power(KW) : 3
Rated Water Pressure: 6.5 Bar



Easily fits into your bathroom or kitchen with its super compact size



Peace of Mind with 5 Year Warranty on Tank



Longer life in tough water conditions with high power heating element



Enhanced Safety with Thermal cutout and Pressure relief valve



Get instant hot water with powerful Heating



Inner Tank	Heating Element	Comprehensive
5 years	2 years	2 years

Instant Water Heater

Product Dimensions

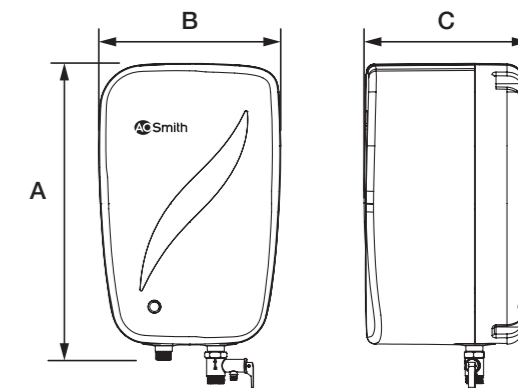

All Dimensions in mm

Model Name	A	B	C
FAST-ON®	371	225	204

* Please refer warranty page for details



FAST-ON® - 3L



Capacity : 3L
Product Color : White Black
Power(KW) : 3 4.5
Rated Water Pressure: 8 Bar



Easily fits into your bathroom or kitchen with its super compact size



Peace of Mind with 5 Year Warranty on Tank



Longer life in tough water conditions with high power heating element



Enhanced Safety with Thermal cutout and Pressure relief valve



Get instant hot water with powerful Heating



Inner Tank	Heating Element	Comprehensive
5 years	2 years	2 years

Instant Water Heater

Product Dimensions

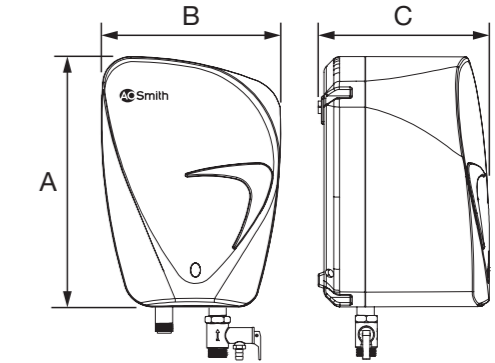

All Dimensions in mm

Model Name	A	B	C
FAST-ON®	306	219	209

* Please refer warranty page for details

FIT IT & FORGET IT !

"Fit it and Forget it!" encapsulates our commitment to durability and reliability. Our products are engineered with high-quality components designed to withstand the rigors of long-term use. Our unique and innovative Blue Diamond® Glass Lining technology and robust 2mm thick steel tank, excel even in challenging water conditions. Moreover, our products boast best-in-class safety features, ensuring a trouble-free experience that lasts. Discover more about our key features...



Ti Steel Tanks

A. O. Smith water heaters now come with a specially designed Titanium steel tank that ensures sturdy construction, longer life and superior quality that is unmatched. The Titanium steel combined with our patented Blue Diamond® coating is the most technologically advanced combination & gives A. O. Smith water heaters resistance to corrosion even in hard waters.



Advanced PUF Technology

The advanced PUF injection ensures uniform and high density foam distribution. Complete coverage of the PUF in between the tank & outer jacket greatly reduces the heat loss. This ensures maximum energy efficiency and power savings.



Fold Back Heating Element

Fits the shape of the tank, ensuring uniform heating and continuous and maximum availability of hot water.



Thermal Cut-Out for Safety

If the water temperature exceeds the highest preset limit then this automatically cuts off the power supply to the water heater for your family's safety.

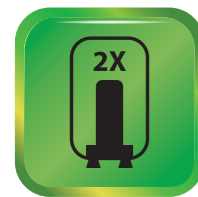

Long-Lasting Anode Rod

A customised alloy that works even in hard water conditions to protect the tank and has 2X lifespan as compared to a magnesium alloy commonly used in most water heaters.

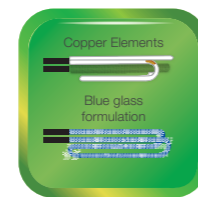

Glass-Coated Heating Element*

Incoloy heating element protected by glass coating to prevent scale formation and extend the life of heating element.

SMARTNESS at your FINGERTIPS.

Hot water requirements vary depending upon the usage. A. O. Smith water heaters are designed to understand this variation and provide hot water accordingly. With different modes ranging from pedicure to double shower, A. O. Smith water heaters are equipped with pre-defined Smart modes, which are convenient and save electricity.

Smart Modes enable...

3C Conservation of Electricity
 Convenience to the customers
 Choice of varied applications

3C Advantages



Conservation of electricity as consumers may choose to use water heater only for specific hot water requirements

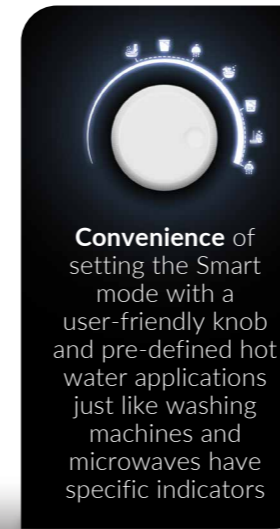

Convenience of setting the Smart mode with a user-friendly knob and pre-defined hot water applications just like washing machines and microwaves have specific indicators



Choice of Varied applications like pedicure, washing clothes, Double bucket bath and many more







Mode / Capacity	Models									
	XPRESS				FINESSE				HeatBot-WiFi	
	6	10	15	25	6	10	15	25	15	25
Pedicure	✓	✓	✓	✓	✓	✓	✓	✓	✓	✓
Bucket	✓	✓	✓	✓	✓	✓	✓	✓	✓	✓
Shower	✓	✓	✓	✓	✓	✓	✓	✓	✓	✓
Washing	-	-	✓	✓	-	-	✓	✓	✓	✓
Mopping	✓	✓	✓	✓	✓	✓	✓	✓	✓	✓
Bucket 2X	-	-	-	✓	-	-	-	✓	-	✓
Shower 2X	-	-	-	✓	-	-	-	✓	-	✓

*Smart Modes: 7 types of smart modes available and vary as per capacity. For more details log on to www.aosmithindia.com

HOW TO CHOOSE YOUR WATER HEATER.

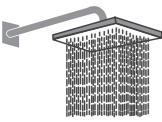
Capacity is the primary criteria which depends on the kind of usage.

 <p>Kitchen</p> <p>Suggested Capacity in Litres 3 / 6</p>	 <p>Bucket</p> <p>Suggested Capacity in Litres 10 / 15</p>	 <p>Normal shower</p> <p>Suggested Capacity in Litres 25</p>	 <p>Body shower panel</p> <p>Suggested Capacity in Litres 35 / 50</p>
 <p>Rain shower</p> <p>Suggested Capacity in Litres 50 / 70</p>	 <p>Bath tub</p> <p>Suggested Capacity in Litres 100 / 200</p>	 <p>Jacuzzi</p> <p>Suggested Capacity in Litres Above 200</p>	



Select the right product for your home. Explore our product discovery tool online!

Presenting the AR Experience. Using your phone camera, choose from our range of A.O.Smith products. This will help you visualize them in your home and kitchens and bathrooms conveniently.



PRODUCTS	DIGITAL	
	SZS-WiFi	SZS-DG
WiFi	✓	-
Alexa Enabled	✓	-
Mobile App	✓	-
Smart Scheduler	✓	-
Smart Modes	✓	-
Energy Tracker	✓	-
Remote	-	✓
Blue Diamond® glass lining	✓	✓
Glass coated heating element	✓	✓
Digital Display	✓	✓
Timer	✓	✓
Energy Meter	✓	✓
Thermal cut-out	✓	✓
Anode rod	✓	✓
Multi Function Safety Valve (MFSV)	✓	✓
Adjustable Thermostat	✓	✓
Capacity	15 25	15 25
Power[W]	2000	2000
Mounting	Wall	Wall

SERIES	MECHANICAL										INSTANT		
	SZS	XPRESS	FINESSE	URBANE	ELEGANCE SLIM	HAS-X	HSE-HAS	ELEGANCE SLIM Neo	ELEGANCE PRIME Neo	ELEGANCE PRIME	VAS-X & VAS-X1	FAST-ON	MINIBOT
Blue Diamond® glass lining	✓	✓	✓	✓	✓	✓	✓	✓	✓	✓	✓	✓	✓
Anode rod	✓	✓	✓	✓	✓	✓	✓	✓	✓	✓	✓	✓	✓
Thermal cut-out	✓	✓	✓	✓	✓	✓	✓	✓	✓	✓	✓	✓	✓
LED Indicators	✓	✓	✓	✓	✓	✓	✓	✓	✓	✓	✓	✓	✓
Multi Function Safety Valve	✓	✓	✓	✓	✓	✓	✓	✓	✓	✓	✓	✓	✓
Glass coated heating element	✓	✓	✓	✓	✓	✓	✓	✓	✓	✓	✓	✓	✓
Temperature control knob	✓	✓	✓	-	✓	✓	✓	✓	✓	✓	✓	-	-
Adjustable Thermostat	✓	✓	✓	-	✓	✓	✓	✓	✓	✓	✓	-	-
Preset Thermostat	-	-	-	✓	-	-	-	-	-	-	-	✓	✓
Express Heat	-	✓	-	-	-	-	-	-	-	-	-	✓	✓
Smart Modes	-	✓	✓	-	-	-	-	-	-	-	-	-	-
Capacity	15 25	06 10 15 25	06 10 15 25	06 10 15 25	15 25	35 50	70 100	10 15	10 15	15 25	35 50	3 5	3
Power[kW]	2	3	2	2	2	2	3	2 3	2	2	2	3 4.5	3 4.5
Mounting	Wall	Wall	Wall	Wall	Wall & Loft	Wall	Wall	Wall	Wall	Wall	Wall	Wall	Wall

DISCLAIMER

1. Product images / color shown may vary from actual model. A. O. Smith reserves the right to amend or modify the design, specifications and features at any time, as and when required without any prior notification. Applicable for all models.
2. Specification and feature are updated till printing date Please refer back page for printing date.
3. Anode: A. O. Smith customized anode has a minimum of 2X more life when compared to a regular magnesium anode of similar dimensions, when tested under standard lab test conditions.
4. Blue diamond: A. O. Smith Smith Blue Diamond® glass lining has a minimum of 2X more durability when compared to a regular glass coating, when exposed to hot water in standard lab test conditions.



WARRANTY

Product Warranty

Your A. O. Smith Water Heater is warranted against defects arising from faulty design, workmanship and materials for a period of 24 months from the date of the invoice, subject to the following conditions:

1. The customer will notify the Company promptly about defects noticed and give the Company or its Authorised Service Provider adequate opportunity to inspect, test and remedy them, for which the customer will deposit the goods, if necessary, with the Company's Office/Authorised Service Provider along with the original invoice.
2. Special warranty from the date of purchase is only applicable for the below mentioned components:

Tank	7 Years
Glass-Coated Heating Element	4 Years
Product Warranty	2 Years

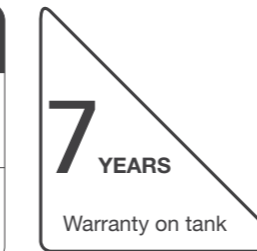

Applicable for XPRESS, FINESSE, HeatBot WiFi Models.

Tank	7 Years
Heating Element	3 Years
Product Warranty	2 Years



Applicable for URBANE & ELEGANCE PRIME Model.

Tank	7 Years
Glass-Coated Heating Element	2 + 2 Years*
Product Warranty	2 Years

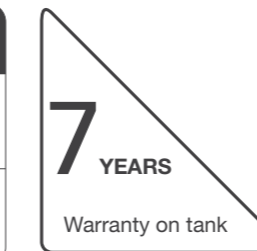

Applicable for \ SZS, SZS-DG, ELEGANCE-SLIM HAS-X, VAS-X, Models.

Tank	5 Years
Glass-Coated Heating Element	2 + 1 Years* 2 Years#
Product Warranty	2 Years



(a) Applicable for MiniBot*, (b) Applicable 2 Years# Warranty on Heating Element on FASTON Models.

*Extended Warranty: Registration of Extended Warranty is valid if customer registers the product within 60 days of purchase. For more details log on to www.aosmithindia.com



proplanet

Series

In addition to water heaters, we've also brought international standard water purifiers to India. Our range of water purifiers offer everything you've thought of, and more. Engineered with the finest technologies, our water purifiers are intuitive, efficient and beautiful. Whether it's top of the line, 5 star rated* A.O. Smith ProPlanet series, Green series, the invisible under the counter models Z2+ and X5+ or the UV models Z1 and X2, find one that best suits your needs.



Ordinary RO water purifiers use four glasses of water to make just one glass of clean water. But A. O. Smith water purifiers with Advance Recovery Technology™ (ART™) save 2X more water*. With high water recovery of 60% in ProPlanet series, you save more than 9000L of water annually*, which is potentially enough for 2 families of 4. Unlike ordinary RO purifiers, the water doesn't bypass the RO membrane. Instead, we pass 100% of the water through it. What this means is that all the water is purified with minimal wastage.